

1

2

3

4

5

6

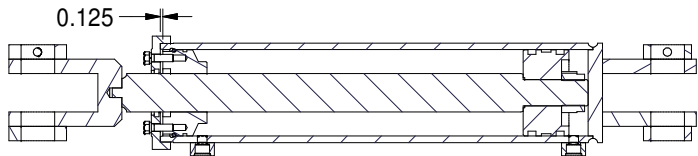

SECTION J-J

APPROVED BY:

NAME: _____

DATE: _____

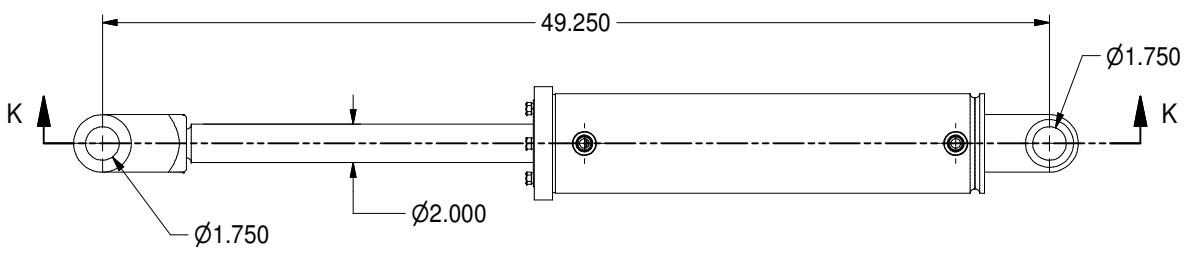
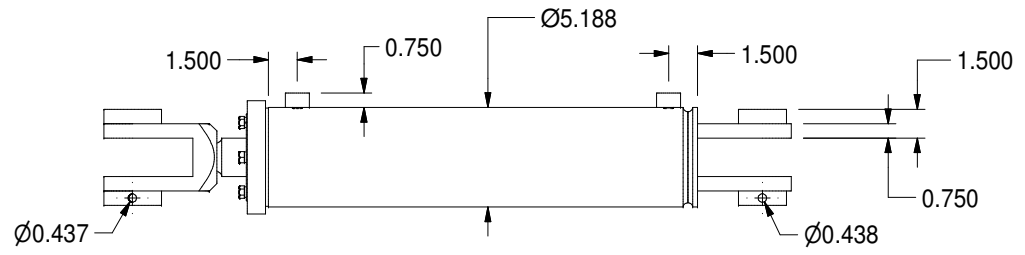
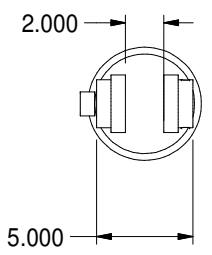
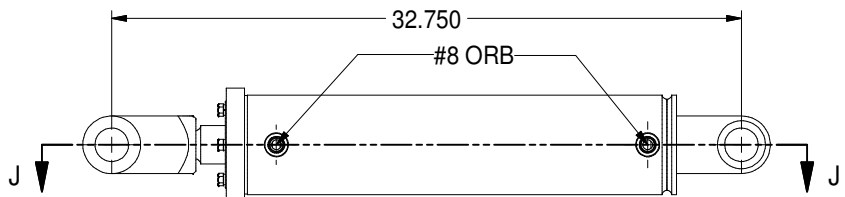
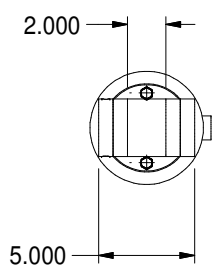

SECTION K-K
SCALE .1

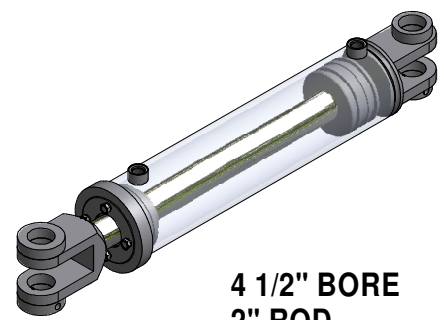

4 1/2" BORE
2" ROD
16 1/2" STROKE



THUNDER BAY HYDRAULICS
 701 MONTREAL STREET
 THUNDER BAY, ON P7E 3P2
 TEL: (807) 623-3151
 FAX: (807) 623-5692

PROJECT/CUSTOMER INFO: MOBILE EQUIPMENT		DSGND: J.F	DATE: 15/08/2007
		CHKD:	DATE:
SCALE: SCALED TO FIT			
SHEET SIZE: A	SHEET: 1 OF 15	FILENAME: TBH_4433 ASSEMBLY EXT.iam	
TITLE: STEERING CYLINDER			
DRAWING No: TBH_4433			REVISION: A

DATE	INITL	DESCRIPTION	REV

1

2

3

4

5

6